

THE KANSAS SADDLE HORSE ASSOCIATION

2009 RULEBOOK

CONSTITUTION	3
BY-LAWS.....	4
CONDUCT OF SHOWS	9
GENERAL RULES	11
JUDGES.....	15
PROTESTS.....	15
PENALTIES.....	16
ANNUAL AWARDS.....	16
SHOW CLASSIFICATION.....	17
FACILITY STANDARDS.....	19
SPECIAL ANNUAL AWARDS	19
MEMBERSHIP.....	22
APPROVED CLASSES.....	22
1. REGISTERED AMERICAN SADDLEBRED HORSES	22
2. REGISTERED APPALOOSA HORSES	24
3. REGISTERED ARABIAN AND HALF-ARABIAN HORSES	24
4. DISCIPLINED RAIL	24
5. ENGLISH PLEASURE.....	24
6. EQUITATION DIVISION.....	25
7. FOX TROTTERS.....	26
8. HUNTER.....	26
9. LEADLINE	26
10. MINIATURE HORSES	26
11. REGISTERED MORGAN HORSES	26
12. REGISTERED PAINT/PINTO HORSES	26
13. REGISTERED PALOMINO/BUCKSKIN/DUN HORSES	26
14. PASO FINO HORSES	27
15. PLEASURE DRIVING	27

16.	PONY DIVISION.....	27
17.	REGISTERED QUARTER HORSES	27
18.	REINING OPEN	27
19.	ROADSTER HORSES	27
20.	SIDESADDLE LADIES.....	27
21.	SHOWMANSHIP AT HALTER	27
22.	REGISTERED TENNESSEE WALKING HORSES.....	27
23.	TRAIL HORSE.....	28
24.	VERSATILITY CLASS.....	28
25.	WESTERN PLEASURE	28
26.	WESTERN RIDING	28

CLASS DESCRIPTIONS..... 29

1.	REGISTERED AMERICAN SADDLEBRED HORSES	29
2.	REGISTERED APPALOOSA HORSES.....	31
3.	REGISTERED ARABIAN & HALF-ARABIAN HORSES ...	32
4.	DISCIPLINED RAIL	33
5.	ENGLISH PLEASURE	34
6.	EQUITATION DIVISION	34
7.	FOXTROTTERS	36
8.	HUNTER.....	36
9.	LEADLINE	37
10.	MINIATURE HORSES	38
11.	REGISTERED MORGAN HORSES.....	38
12.	REGISTERED PAINT/PINTO HORSES.....	39
13.	REGISTERED PALOMINO/BUCKSKIN/DUN HORSES	39
14.	PASO FINO HORSES	40
15.	PLEASURE DRIVING, OPEN	41
16.	PONY DIVISION	42
17.	REGISTERED QUARTER HORSES	43
18.	REINING OPEN.....	43
19.	ROADSTER HORSES	43
20.	SIDESADDLE LADIES	44
21.	SHOWMANSHIP AT HALTER	44
22.	REGISTERED TENNESSEE WALKING HORSES	45
23.	TRAIL HORSE.....	47
24.	VERSATILITY CLASS	49
25.	WESTERN PLEASURE.....	49
26.	WESTERN RIDING.....	49

REINING PATTERNS..... 52

BEGINNER’S EQUITATION PATTERNS..... 55

CONSTITUTION AND BY-LAWS
The Kansas Saddle Horse Association, Inc.

CONSTITUTION

Article I NAME

The name of this Association shall be THE KANSAS SADDLE HORSE ASSOCIATION, INCORPORATED.

Article II OBJECTS

1. To promote the education of the people of Kansas in breeding, care, use, handling, and development of horses and horsemanship.
2. To encourage good sportsmanship and proper conduct among horsemen and horsewomen and to foster good fellowship among all persons interested in Saddle Horses.
3. To encourage proper and humane handling and care of horses and to prevent cruelty to animals.
4. To assist in establishing a horseshow circuit in the state of Kansas.
5. This Association shall be a non-profit organization and shall not be conducted for pecuniary profit, and there shall be no capital stock.

Article III MEMBERS

Any person who shall be recommended by a member of the Association shall be entitled to a membership in this Association upon the payment of a membership fee as fixed by the Association, unless said application for membership shall be rejected by the negative vote of a majority of the Board of Directors. Any individual, firm, partnership, Association, or corporation, doing business in the state of Kansas, who shall be recommended by a member of this Association, shall be entitled to a corporate or sustaining membership in this Association upon compliance with such conditions and the payment of such fees as may be determined by the Board of Directors, unless said applicant for membership shall be rejected by the negative vote or a majority of the Board of Directors. Any individual who is eligible for membership in this Association may purchase more than one membership, but shall be entitled to only one vote at any regular or special meeting of this Association.

Article IV OFFICERS AND DIRECTORS

The officers of the Kansas Saddle Horse Association shall be a President, a 1st Vice President, a 2nd Vice President, a Secretary, and a

Treasurer who shall be selected from the Board of Directors of said Association and voted upon by the membership. The Board of Directors shall consist of not less than three nor more than twenty one members. The Board of Directors shall be elected in the following manner: At the first annual meeting, one third of the directors shall be elected for one year, one third for two years, and one third for three years. At each succeeding annual election, the vacancies occurring shall be filled by electing directors for periods of three years, and the term of Directors so elected shall commence on the first day of the month following their election. NO member shall hold more than one office at a time or be eligible to serve more than two consecutive terms in the same office, except at the pleasure of the Board of Directors.

The duly elected President and Vice President of the Junior Kansas Saddle Horse Association shall be voting members of the Board of Directors of the Kansas Saddle Horse Association and shall be in addition to the number of Directors provided above.

Article V MEETINGS

All meetings of the members of this Association shall be held annually at such time and place as shall be designated by the Board of Directors of this Association.

Article VI AMMENDMENTS TO THE CONSTITUTION

The Constitution of the Association may be amended at any regular or special meeting by a two-thirds vote of the members present, provided that the proposed amendment shall have been read at one previous meeting or provided copies of the amendment shall have been sent to the members with the notices of said meeting.

BY-LAWS

Article I DUES

The dues of each member or saddle club shall be set annually at the general membership meeting. Each member whose dues are fully paid, and who is in good standing shall be entitled to one vote at any regular or special meeting of the members of the Association. Such votes shall be cast in person, provided however, that votes may be cast by mail when a copy of the question, motion, or resolution is attached to such votes. A member shall cease to be a member when his or her dues become delinquent.

Member show fees shall be set annually at the general membership meeting. A show thus becoming a member of the Association shall be bound and governed by the Associations official horse show rules and shall be entitled to the benefits of the yearly horse show rating and the services of the rules committee in enforcing penalties.

Article II OFFICERS

PRESIDENT

The President shall be the chief executive officer of the Association; he shall preside at all meetings of members and directors; he shall have general and active management of the Association; he shall see that all orders and resolutions of the Board of Directors are carried into effect, subject to the right of the directors to delegate any specific power, except such as may be by statute exclusively conferred upon the President to any officer or officers of the Association; he shall execute or cause to be executed all contracts of the Association. He shall appoint any and all committees which in his discretion are necessary or proper and shall be an ex-officio member of all said committees; he shall have the general powers of supervision and management usually vested in the office of the President.

VICE PRESIDENTS

In the absence of the President, or in case of disability of the President, the 1st Vice President shall perform the functions of the office of the President and shall further be in responsible charge of the annual KSHA Horse Show. A 2nd Vice President shall serve in the absence of the 1st Vice President, and be in responsible charge of the annual awards convention. The KSHA Board of Directors will advise the 2nd Vice President concerning matters of budget and awards.

SECRETARY

The secretary shall attend all sessions of the Board of Directors and all sessions of the members and act as the clerk thereof, and record all votes and the minutes of all proceedings in a book to be kept for that purpose and shall perform like duties for the standing committees when required. He shall give or cause to be given notice of all meetings of the members and the Board of Directors when required to do so by the President, and shall perform other such duties as shall be prescribed by the Board of Directors or President. He shall be an ex-officio member of all committees.

TREASURER

The treasurer shall keep full and accurate accounts of receipts and disbursements in books belonging to the Association, and shall deposit all moneys and other valuable effects in the name and to the credit of the Association, in such depositories as may be designated by the Board of Directors. He shall disburse the funds of the Association as ordered by the Board of Directors or on order of the executive committee, taking proper vouchers for such disbursements, and shall render to the President

and directors at the regular meeting of the board or whenever they may require it, an account of all his transactions as treasurer and of the financial condition of the Association. He shall, if requested or required, give the Association a bond to be paid for by the Association in such sum and with sureties as may be satisfactory to the board for the faithful performance of the duties of his office and the restoration of the Association in case of his death, resignation, or removal from office, all books papers, vouchers, money, and other property of whatever kind in his possession belonging to the Association. The treasurer shall prepare and file with the secretary not later than January 20, each year a full and complete financial statement covering the preceding year, the balance sheet and profit and loss statement of which shall be published in the next succeeding issue of the official organ of the Association or mailed separately to each of the members. The office of secretary and treasurer may be held by the same person if the directors deem it advisable.

Article III BOARD OF DIRECTORS

The board of directors shall consist of not less than three nor more than twenty one members to be chosen from the various communities of the state to the end that the board may be representative of the state as a whole. The business, activities, and property of this Association shall be managed and controlled by the board of directors who shall meet at least once each year and as often as may be deemed necessary. Special meetings of the board of directors may be called at any time and place by the president, and shall be called by the president at any time upon the written request of a majority of the board of directors. Only members in good standing as is reflected by the books of the treasurer of the Association shall be eligible for membership on the board of directors.

The duly elected president and vice president of the Junior Kansas Saddle Horse Association shall be voting members of the Board of Directors.

Article IV EXECUTIVE COMMITTEE

The executive committee of this Association shall consist of the president, secretary, and three members who shall be elected by the board of directors from among their number or from the membership of the Association, but who shall not hold any other office elective by the board of directors. The executive committee shall, in the absence of specific directions from the board of directors, have the sole power to authorize the execution of any contract on behalf of the Association or the expenditure of any of its funds. Any delegation of power to the executive committee by the directors shall not operate to relieve said board of directors or any member thereof, of any responsibility imposed upon it or him. Meetings may be called by the president or by the request of a majority of the members of this committee.

No member shall hold more than one office at a time or be eligible to serve more than two consecutive terms, except at the pleasure of the board.

Article V ELECTIONS

The election of directors shall be held by mail ballot sent to each member at least thirty days prior to the annual meeting. A nominating committee of not less than five nor more than nine members shall be appointed by the president. It shall be the duty of said nominating committee to confer with members from throughout the state and to nominate at least two members as candidates to replace each director whose term expires at the time of the annual meeting.

It shall be the further duty of the nominating committee to cause a ballot with the names of the nominees so selected, printed thereon, to be mailed to each member at least thirty days prior to the annual meeting. It shall be the privilege and duty of each member to properly mark his or her ballot and mail or deliver to the secretary of the Association or other person designated by the nominating committee, in order to reach the person so named two days prior to the time the meeting is called to order on the day of the annual meeting at which time the polls shall be closed. Any member may write in names of candidates other than those selected by the nominating committee. The president shall appoint a committee of judges of elections (none of whom shall have been members of the nominating committee), whose duty it shall be to count the ballots and announce the results of the election to the members during the annual meeting.

Other rules pertaining to the marking of ballots and casting of votes according to usual practice shall accompany each ballot. Only members whose dues have been paid at the time the polls are closed will be entitled to vote.

Article VI MEETINGS

ANNUAL MEETING

There shall be an annual meeting of the members of the Association in each calendar year, on such day and time as may be fixed by the board of directors and said board of directors shall cause notice to be given of such meeting by mail to each member of the Association in good standing, at least ten days before the date and time fixed for such meeting by the board of directors.

SPECIAL MEETINGS OF MEMBERS

Special meetings of members may be called by the president, by the board of directors, or by not less than twenty-five percent of the members of the Association who are not delinquent in their membership dues.

1. "Quorum". The members of the Association present at the annual meeting shall constitute a Quorum.
2. Three or more members of the board of directors shall constitute a Quorum for the transaction of any business and the act of the majority of the directors present at the meeting at which a quorum is present shall be the act of the board of directors unless the act of a greater number is required by law or by the by-laws. The board of directors shall be mailed a notice of meeting at least five days previous to such meeting.
3. The majority of the Executive Committee shall constitute a quorum for the transaction of business. Seven days previous notice of meetings shall be mailed to members of this committee, with a follow-up confirmation via personal contact (email with immediate response or telephone).

Article VII ELECTION OF OFFICERS

Officers of the Association shall be elected by a vote of the membership. The annual meeting of the election of officers shall be held within thirty days of the time of the annual election of directors by the members.

Article VIII VACANCIES

1. If the office of any director or officer of the Association becomes vacant by reason of death, resignation, disqualification or otherwise, the remaining directors shall elect a successor who shall hold office during the unexpired term of his predecessor and until this successor is elected and qualified.
2. Any director or other officer may resign his office at any time, such resignation to be made in writing, and to take effect from the time of its receipt by the Association, unless some time be fixed in the resignation, and then from that date. The acceptance of a resignation shall not be required to make it effective.
3. Any officer may be removed at any time for any reason upon the vote of two-thirds of the entire membership of the board of directors.
4. The office of any director who fails to attend three consecutive meetings of the board shall be declared vacant and a successor elected by the board to fill the unexpired term.

Article IX LIABILITIES

The Association shall not have the power to subject itself to an indebtedness exceeding the current funds at the time in the treasury and the members of this Association shall not be liable for any debts of the said Association.

Article X COMPENSATION OF DIRECTORS

Directors of such, shall not receive any salary for their services but by resolution of the board may be reimbursed for any actual necessary expenses incurred by reason of their directorship.

Article XI AMENDMENTS TO BY-LAWS

The by-laws of this Association may be adopted or amended at any regular or special meeting by a two-thirds vote of the members present, provided the proposed amendment shall have been read at one previous meeting or provided copies of the amendment have been sent to the members with the notice of said meeting.

By-Laws of this Association may also be amended by mail, providing ballots are sent to all members setting forth in detail the proposed amendments and allowing members twenty days in which to cast their ballots. Two-thirds of the votes so cast must be in affirmative to authorize such amendments.

CONDUCT OF SHOWS

1. To hold a Member show, application shall be sent to the Show Chairperson of the Kansas Saddle Horse Association (KSHA). Show dates must be approved by the Show Chairperson.

2. A preliminary showbill should be sent to the KSHA Show Chairperson at least seven (7) weeks prior to the show. Upon approval, the showbill will be returned to the Show Secretary for printing. Showbills must be mailed to all KSHA members. **SHOWBILLS SHALL BE MAILED TO ALL KSHA MEMBERS THREE WEEKS PRIOR TO THE SHOW OR EARLIER.** Failure to comply with these guidelines will result in a \$100 fine and e-mail correspondence will not be accepted. Showbills must be submitted for approval via ground mail and postmarked on or before the 7-week deadline.

3. Any shows adding classes after the showbill is mailed must notify all KSHA members in writing 10 days or more prior to the show. **CLASSES ADDED AT THE SHOW WILL NOT QUALIFY FOR KSHA YEAR END POINTS.**

4. The member shows shall furnish the KSHA Show Chairperson a record of the judge's placings for each class as well as all the class entries. This record should give the owners' names, horse's name and exhibitor's name, and should be received within 30 days from the date of the show. Failure to comply with this rule could result in the omission of

the show results from the tabulation for Annual Awards.

5. Each Show will provide a qualified judge. (see Judges)
6. Every Member show shall appoint a Ring Committee which shall be responsible for the enforcement of the Rules. They shall operate under the authority of the KSHA Rules and Regulations. Controversial matters shall be referred to the KSHA Rules Committee whose decision shall be final.
7. Every Member show must have a competent and duly instructed Ringmaster whose duties shall be to assist the Judge by giving commands and maintaining order and safety in the ring during the showing of all classes. A Paddock Judge or Steward is recommended to check exhibitors' attire and tack prior to the class. Neither the Paddock Judge nor the Ringmaster will influence the decision of the Judge.
8. Every Member show shall furnish a qualified announcer, concession stand, bleachers, telephone, clean restrooms with adequate facilities close enough for exhibitors to use between classes, and a working spigot with fresh running water placed in a position where water can be easily accessed. Phone numbers for veterinarian and farrier on call must be posted, and published on the showbill itself. Parking facilities should be adequate to accommodate large trailers and have solid enough footing that the vehicles do not become stuck. They shall also furnish or have available on immediate call a veterinarian, farrier, and emergency medical services. Every member show shall meet the qualifications of Facility Standards noted on page 19.
9. The Show Committee shall be prepared to water down a dry ring for dust control or take adequate action to dry a wet muddy ring. In either case, suitable footing for all types of horses must be provided.
10. If the classes include those for Saddlebred horses, then stall facilities are recommended.
11. Each Member show must provide on its entry blank a space for the designation of the registration number, height, and sex of each entry. It shall be the duty of each exhibitor to give the correct height of each horse or pony measured in the shoes which will be worn at the time of showing. Recommended standard entry forms may be obtained from KSHA.
12. Member shows should make judge's evaluation cards available to exhibitors at the show office.

GENERAL RULES

1. A period of not more than 3 minutes may be allowed to enter the ring. A maximum of 5 (five) minutes will be allowed for tack changes with prearranged notification to the gate person/paddock master (and announcer, if attainable). At the expiration of this period, the gates shall be closed and no other horses will be allowed to enter.
2. The judging of a class shall be suspended for a period not to exceed seven (7) minutes to allow repair to be made to equipment or the horse re-shod. A given horse may stop a second time for re-shoeing if there is time remaining of his original seven minutes. If not, he must continue barefoot or leave the ring.
3. STALLIONS are barred from all classes restricted to Ladies in the American Saddlebred and Morgan divisions. Youth are prohibited from showing Stallions, except that youth age 13 & over may show Miniature stallions in classes restricted to Miniature horses.
4. All horses shall be serviceably sound for the intended purpose. Use of stimulants, depressants or tranquilizing drugs is prohibited.
5. Silver mounted equipment may be used in western classes but this equipment shall not count over a good working outfit.
6. Tapaderos or hooded stirrups are prohibited in all classes except Leadline, Ladies Sidesaddle, Walk-Trot, and Paso Fino.
7. Australian type saddles are permitted provided that they have a horn.
8. In any class, all entries must be on the same basis. It shall not be permissible for a show to accord free entries, transportation, or other expenses to an exhibitor.
9. In performance classes, there shall be no substitution of riders or drivers after the class has started.
10. Where a class entry fee is charged, it shall be forfeited if the horse is not shown unless a veterinary certificate is furnished certifying such animal to be unable to show.
11. Post entries may be accepted or refused at the discretion of the local show management.
12. An amateur, for horse show purposes, is one who rides or drives for a love of the sport, not as a professional for a livelihood, and who does not receive monetary payment for his/her services. All Beginners' classes are for amateurs only.

13. Exhibitors' numbers are to be worn on the exhibitors' backs or on each side of the horse in classes, and in such location and manner as to be readily and clearly visible at all times. In driving classes, the number may be placed on the back of the cart.
14. Sidesaddles are prohibited in any class other than Ladies Sidesaddle and in Leadline.
15. A KSHA member shall not be required to have a USEF Amateur Card except at USEF Member shows. A professional may enter any class unless it is restricted to amateur exhibitors.
16. NON-REGISTERED HORSES--All classes not limited to a specific breed are open to both registered and non-registered horses.
17. Pattern and Courses for Hunter, Showmanship at Halter, Reining and Trail must be posted prior to the first class of the show.
18. All of the available arena shall be utilized in performance classes, unless physically impossible.
19. For the safety of exhibitors, other entries or spectators, any horse deemed unruly, unsafe or unsound may be excused or removed from the ring by the judge. Headers are not allowed in riding classes.
20. Any conduct, inside or outside the arena, (such as, but not limited to yelling, coaching, towels, whips, bags, etc.) which disturbs or interferes with other exhibitors is prohibited. Incidents or accidents that occur outside the arena shall be addressed by the show management. This is not the responsibility of KSHA.
21. References to Hackamore mean a rawhide braided, leather braided, or rope bosal. Mechanical hackamores are prohibited.
22. References to a Snaffle Bit in Western classes mean the use of a smooth snaffle bit with a broken mouthpiece (conventional "O" ring, egg-butt, or "D" ring) and rings no larger than 4".
23. Bosals and ring snaffles with 2-4" rings may be used on any horse of any breed five (5) years and under in any Western Pleasure class.
24. References to Standard Western Bit mean the use of a curb bit that has a solid or broken mouthpiece, has shanks and acts with curb action from a curb strap or chain.
25. Any solid iron under the jaws, regardless of how padded or

covered, is prohibited.

26. All horses shall be shod in accordance with the latest revisions of USDA regulations and/or individual breed requirements. Any artificial appliances other than those permitted in division rules are prohibited, except at the discretion of show management, which will be announced.

27. The Kansas Saddle Horse Association shall be recognized as a Horse Association. No mules or donkeys allowed in classes.

28. Anyone receiving 100 points in any one beginners' riding class will receive a year end certificate and will no longer be eligible for year-end awards in any beginning riding classes in subsequent years. Exceptions to the walk/trot rule may be obtained from the KSHA Board of Directors in writing—prior to the show.

29. A safety helmet is permitted in any class.

30. It is the tradition of the show ring that riders and drivers be correctly attired for the class in question, that attendants be neatly dressed and horses be properly presented. Attire is based on traditional and general present-day customs consistent with breed standards. Judges, at their discretion, may authorize adjustments to attire due to weather related conditions. Regulation safety headgear of any style may be worn in any class, for example, a hunt-style cap may be worn in a western class.

Saddle Seat Attire

Informal: Conservative colors in herringbone, pin stripes and other combinations of colors that appear to be solid. Solid colors include black, blue, grey, dark burgundy, dark green, beige or brown jacket with matching jodhpur, derby hat, gloves, and jodhpur boots. Day coats in contrast to darker jodhpur are permitted in pleasure classes. Gaudy colors should be avoided. Only informal dress is permitted in Pleasure Equitation classes, day or night.

Formal: Even more conservative attire and accessories are required for evening equitation, park, and 3-gaited performance classes. Solid colors include dark grey, dark brown, dark blue or black tuxedo-type jacket with collars and lapels of the same color, top hat, and jodhpurs to match and gloves or dark-colored riding habit, accessories and jodhpur boots. Formal jackets in contrast to darker jodhpur are permitted in park and 3-gaited performance classes. Gaudy colors should be avoided. Formal riding habits are not to be worn before 6:00 p.m. and are not mandatory after 6:00 p.m.; exhibitors competing on Pleasure horses have the option to wear formal attire in Open equitation classes as specified by the rule.

Misc.: Spurs of the unrowelled type, whips or crops are optional.

Western Attire

Riders must wear Western hat or regulation safety headgear, long-sleeved shirt with collar, trousers or pants and boots. Chaps, ties, gloves and spurs are optional. A vest, jacket, coat, and/or sweater are optional.

Hunt Seat Attire

Attire shall be traditional hunter-style coats of any tweed or melton for hunting (conservative wash jackets in season), breeches or hunter jodhpurs, dark hunting cap, derby or protective headgear and appropriate boots. A stock choker or four in hand with any color shirt is correct. Shad bellies are prohibited except in Show hack and Sidesaddle. When management permits Hunter or Hunter Seat Equitation riders to ride without jackets, riders must wear traditional, short or long-sleeved riding shirts with chokers or ties. Polo shirts are not permitted except in unjudged warm-up classes.

Regulation Safety Headgear:

Riders in all classes where jumping is required and when jumping anywhere on the show grounds must wear regulation safety headgear (Exception: Trail classes). Headgear harness must be secured and properly fitted.

Miscellaneous: In all classes, gloves, hunter crop or bat, and spurs are optional.

31. KSHA Requires show management to split rail work classes with 16 or more entrants in any KSHA point class specifically for junior riders, junior horses or beginning riders. (Example: Saddleseat Pleasure 18 and under, Beginning Walk/Trot Hunt Seat Pleasure 19 & Over, Western Pleasure Junior Horse). Non-KSHA point classes will be conducted at show management's discretion. When a rail work class is split, a final run-off class is required, consisting of not more than six horses from each split. All splits and the final run-off class must run consecutively to each other. Awards should only be given in the final run-off class, and not in the individual splits.

32. No more than eight horses shall be allowed to show at a Hand Gallop at one time.

33. For KSHA, youth shall be defined as 18 and under for classes and year end awards, and for USEF youth shall be defined as 17 and under. USEF includes Saddlebreds, Arabians, and Half-Arabians.

34. All adults riding in the 19 and over or "adult" beginner classes must be KSHA members and have a KSHA Beginner Card. This card is not required for the youth or 18 & under classes. To obtain the card an individual must fill out the official application, available on the Web site, and submit it to the

KSHA Board of Directors for approval. The individual will be able to show in Beginner classes while approval is pending by the Board, but not until the form has been submitted.

JUDGES

1. The horse show Judge will have complete knowledge of the Rules of the classes to be judged. To the best of his/her ability, the Judge will give an unbiased decision according to the rules of the class. No contact may be made with the Judge without the approval of the Show Committee and only after the exhibitor has completed showing. No Judge shall be influenced by comments from the Ringmaster or Announcer.
2. The Judge's name will be listed on the showbill. A current list of prospective Judges is available from the KSHA Show Chairperson.
3. No horse may be shown before a Judge that has been sold by said Judge or by his employees within a period of six (6) months prior to the show.
4. No exhibitor may show before a Judge who boards, rides, or trains (for horse show purposes) any horse under said exhibitor's ownership or lease within a period of six (6) months prior to the show.
5. A judge may not operate in any capacity other than judging at a show.
6. A Judge may work no more than two KSHA member shows per year and said two shows are not to be consecutive.

PROTESTS

1. Any exhibitor lodging a protest must first deposit with the Horse Show Secretary, a check in the amount of \$50.00 made payable to KSHA. All protests must be in writing, signed by the protester, and must be lodged with the Show Secretary within 48 hours after the award is made. All protests must be immediately referred to the KSHA Rules Committee whose decision shall be final. If the protest is sustained, the entries standing next in award will be moved up. If the protest is not sustained, the fee will be forfeited.
2. The Kansas Saddle Horse Association will bear all expenses pertaining to the protest up to the amount of the protest fee. Expenses over and above this amount shall be borne equally by the member show and KSHA.

PENALTIES

1. Any act of discourtesy or disobedience to a Judge, or to an official of this Association, or of a member show, by an owner, exhibitor, or his agent, employee, rider, driver, stable manager or groom, or by a parent or husband or wife or other close relative of such competitor, shall be deemed to constitute conduct prejudicial to the best interest of this Association. Upon request of the KSHA Rules Committee by the Secretary or any member of the horse show committee, the KSHA Rules Committee shall have the power to debar from showing at any member show, any or all horses or persons from the stable concerned, for such a period of time as they may determine the offense warrants. The KSHA Rules Committee will immediately notify all members of any such action.
2. If a member fails to settle his or her account at one of our member shows, and if the show so notifies KSHA in writing, KSHA will write a certified letter to that member informing him or her that points earned at that show will not be counted toward year end awards, nor will any points earned at subsequent shows during that same year be counted until either the show management notifies KSHA that the account has been settled, or until the KSHA board of directors rules the account settled.

ANNUAL AWARDS

1. Awards will be presented to the owners/lessees of the horses in performance classes, and the riders in equitation classes, earning the six (6) highest positions in each division and subdivision listed in the current rules of approved classes, subject to having placed in three (3) or more of the accredited classes held during the calendar year in member shows. The Board of Directors must approve all classes prior to the start of the season.
2. KSHA will use every care to achieve accuracy in computing the show classification and tabulating the placings, but not be liable for the failure of any member show to file the results of their show nor for errors or omissions in their making thereof, nor responsible beyond the point of accuracy in computing the final ratings from the results submitted by the proper authorities of each show.
3. The cumulative score earned by an entry within the respective classification shall be included in the reckoning of the final placing regardless of transfer of ownership within the period of competition. The owner/lessee of the horse at the time of scoring its last point shall be the recipient of the award.
4. The entry scoring the highest number of points in its

classification at Member shows held throughout the calendar year shall be considered the winner; the entry scoring the next highest number of points shall be awarded the second place; and so on until six places have been determined. In the case of a tie, two same-place ribbons will be awarded, for example, 1st, 2nd, 2nd, 4th, 5th, and 6th. Duplicate awards will be given in case of ties for first place.

5. In figuring the final placings for annual awards, points for classes with approved age and sex splits and/or championship or stake classes, will count toward the approved class. In cases of Western pleasure Open, English Pleasure Open and Hunt Seat Pleasure Open Championships, it shall be the option of the exhibitor/participant to notify the KSHA Show Chairperson in writing within 10 days of the show as to which class the points should be credited. For the points to count, the exhibitor must have shown in a qualifying class.

6. In any and all cases not specifically covered by the rules and regulations, the right is reserved by the Recording Secretary to follow such procedures as will, in his/her best judgment and discretion, best serve the common interest of the exhibitors, the member shows and the Association. Such discretionary judgment shall be approved by the KSHA Rules Committee.

7. Any question or dispute in connection with the computation of these awards shall be referred to the KSHA Rules Committee for decision. Its verdict shall be final.

8. A final record showing the tally and score of each entry participating at any Member show will be kept in the files of the Recording Secretary, and information in connection therewith will be available upon request for 60 days following the awards banquet.

9. Annual award points will be accumulated from the time of receipt of horse nomination and membership dues for the current years' shows.

10. Requests to donate new perpetual trophies are no longer being accepted (as of 2004). Perpetual trophies currently in circulation will be permanently retired at the discretion of the Board of Directors. Any new requests to sponsor a Special Annual Award shall be considered by the Board. Requests include a three (3) year commitment, and the award requirements shall include multiple classes or divisions.

11. KSHA encourages individual class sponsorship for any Annual Award. Class sponsors are responsible for reimbursement to KSHA for the cost of the annual award.

SHOW CLASSIFICATION

The Kansas Saddle Horse Association offers a yearly horse

show rating system under the regulations set forth:

1. To qualify as an accredited "A" Show, the entry fee must be \$5.00 or less, payback is optional and ribbons &/or awards to six (6) places are required. (EXCEPTION: Payback shall not be permitted in Equitation, Horsemanship or Showmanship classes.)
2. To qualify as an accredited "AA" Show, the class entry fee shall be \$6.00 or more and payback is optional. Ribbons &/or awards to six (6) places are required and trophies are optional. (EXCEPTION: Payback shall not be permitted in Equitation, Horsemanship or Showmanship classes.)
3. To qualify for an approved KSHA Show, the showbill must include 80% KSHA approved classes exclusive of stake and championship classes unless prior approval is given by the KSHA Show Chairperson. At least five (5) open classes must be included that allow entries of any breed including unregistered horses.
4. It is recommended that at least 30% of the entry fees be paid back, to at least the top three (3) placings.

5. Points will be computed on the basis of:

	A Show		AA Show	
Placing	4 horses or less	5 horses or more	4 horses or less	5 horses or more
1 st	6	8	8	10
2 nd	5	7	7	9
3 rd	4	6	6	8
4 th	3	5	5	7
5 th	2	4	4	6
6 th	1	3	3	5

If classes are split, each division must be offered and the total count for points will be on the total number of horses contained within the split. Points from splits go into the approved class.

6. The KSHA show rating will appear on the premium lists, showbills and programs. Six (6) placings shall be awarded in each class.
7. In order to receive the benefits of the yearly show rating, the use of a set of uniform show rules and the services of the Rules Committee in enforcing penalties, any horse show, by payment of the Show Fee, may become a Member show of the Kansas Saddle Horse Association and then be governed by their rules. Show Management not complying with the rules shall be put on probation and/or have its show dropped from the list of KSHA approved shows.

8. Application and preliminary list of classes must be sent for approval at least seven (7) weeks prior to said show, in order to qualify as a member show. Final showbill must include the list of classes, location, date, time, and Judge's name, show classification, entry fee and payback. Show dates for KSHA will only be approved for the season of April 1st through October 31.

9. Double judged shows will be allowed in KSHA at a charge of \$35 for 'A' shows and \$40 for 'AA' shows per judge per day.

FACILITY STANDARDS

Calling a Show: There must be three (3) members of the KSHA Rules Committee present in order to call (cancel) a show. If only one or two members are present, they may appoint KSHA members to temporarily fill those positions. If all three committee members agree that the facilities are (or have become) unsafe or inadequate (i.e. standing water in the show arena) they may cancel the KSHA recognition for that show. From that point, no classes held will count for KSHA points. If the rules committee rules that the show arena is or has become unsuitable for horses, show management may move the show to an alternate location, or hold the show in the grass if it is approved by the rules committee as safe and adequate. **LOSS OF STATUS MUST BE ANNOUNCED, AND MUST BE DISPLAYED AT ENTRY TABLE.**

Facilities: The minimum size for any KSHA show area should be 60 feet by 110 feet, or a comparable area. The show arena must have safe and reasonably level footing that should not be more than four inches deep. Parking facilities should be adequate to accommodate large trailers and have solid enough footing that the vehicles do not become stuck.

SPECIAL ANNUAL AWARDS

A perpetual award is the property of KSHA and must be returned each year regardless of the number of times anyone wins the award.

Junior Exhibitor of the Year: English and Western Champion and Reserve Champion awards and ribbons to six (6) places will be presented to the Junior KSHA members who earn the most points in showmanship as well as riding classes that require a canter or lope and are restricted to exhibitors 18 years and under. Points are to be based on the current KSHA point system.

Cleo Ray Perpetual Trophy: For high point rider in American Saddlebred 3-Gaited Pleasure, English, Youth. Donated by the Walter Zitlow Family.

Walking Horse Park Pleasure Perpetual Trophy: For Park Pleasure

horse accumulating the most points. If there are no Park Pleasure or Show Pleasure horses, award will be presented to Plantation Pleasure Champion. If there are no Plantation Pleasure horses, award will be presented to Country Pleasure Champion. Donated by the Kansas State Tennessee Walking Horse Association.

Mr. Nero Annual Trophy: Presented to the Beginners Walk-Trot only, 18 and under western rider accumulating the most points in Walk-Trot Western Pleasure and Beginners Equitation Walk-Trot Western classes. Donated by Sarah and Betty Robinson.

Battle Banner Perpetual Trophy: For the 5-gaited horse accumulating the most points. Donated by the Kansas American Saddlebred Association in honor of Cleo Ray.

High Point Perpetual Trophy: The Youth receiving the most points in the Youth Pleasure Classes requiring a canter or lope. Donated by Mr. and Mrs. William Peppard.

Deer Mist Plaudit Hunter Horse Perpetual Trophy: For the horse receiving the most total points in its respective breed English Pleasure or Working Hunter Under Saddle class, or Hunt Seat Pleasure Open class, and Hunter Hack. The horse must compete on the flat and over fences to be considered for the award. While the horse must have competed in both flat and fences classes, it does not have to qualify in both. Donated by Rising Sun Appaloosas.

Irene Duncan Memorial Perpetual Trophy: For the Trail Horse receiving the highest number of points in trail classes where a lope is required. Donated by Irene Duncan.

The Overall High Point Half-Arabian Horse Award: To be given to the Half-Arabian Horse that has accumulated the most overall points for the year in Half-Arabian classes. The award is sponsored by the Kansas Arabian Horse Society.

The Overall High Point Arabian Horse Award: To be given to the Arabian Horse that has accumulated the most overall points for the year in Arabian classes. The award is sponsored by the Kansas Arabian Horse Society.

Al Paulie Memorial Award: High Point Youth Equitation Perpetual Trophy in memory of Al Paulie. For the Youth who has accumulated the highest total points in all equitation classes requiring a canter or lope. Donated by Bill and Pam Peppard.

Perpetual Unregistered Horse Award: For the unregistered horse receiving the most points. Donated by The Anvil.

Junior Perpetual Award For Sportsmanship: For the youth exhibiting the highest degree of all-around sportsmanship in and out of the ring. Award donated and presented by the Junior Association of KSHA.

Junior Walk/Trot Exhibitor of the Year: Champion and Reserve Champion awards to be presented to the Junior KSHA members who earn the most total points in walk/trot classes restricted to exhibitors 18 years and under and in showmanship classes.

19 and Over Walk/Trot Exhibitor of the Year: Classes that count for this award include Western/English Walk-Trot Equitation, Walk-Trot Western Pleasure, and Walk-Trot English Pleasure. Donated by JR Edwards.

Betty Smyth Memorial Driving Trophy: For the horse accumulating the most points in driving classes. This Traveling Trophy will become the property of the first competitor to win it three times consecutively. Donated by Vicki Seyffer.

Commander's Power Play Award: Given to the American Saddlebred Country English (saddleseat) and Country Western horse with the most points, with points from both divisions to count. Donated by Katie Yaverski.

Betty Robinson Memorial Adult Sportsmanship Award: For the adult exhibiting the highest degree of all-around sportsmanship in and/or out of the ring. Award sponsored by Sarah Robinson.

Irene Zane Registered American Saddlebred Pleasure Perpetual Trophy: For the Registered American Saddlebred horse accumulating the most points in any one Registered ASB Pleasure class. Donated by friends of Irene Zane.

Okies Jasmine Memorial Award: For the Registered Paint/Pinto horse who qualifies in all three Paint/Pinto classes and Trail or Hunter Hack. Award sponsored by Jasmine Tweedel.

High Point Horse Award: For the horse that accumulates the most points in any one class in a single show season. Horses must be KSHA-nominated but may be shown by any exhibitor or exhibitors throughout the year. Award sponsored by a friend of KSHA.

MEMBERSHIP

- 1 Membership Fees will be received annually at the General Membership meeting for the following calendar year.
- 2 Adult Membership--It is required that the owner or exhibitor of any horse in classes for exhibitors 19 years and over be a KSHA member in order to participate in the Annual Awards. Adult memberships shall have one vote each.
- 3 Junior Membership--it is required that riders in equitation classes be a KSHA member in order to participate in the Annual Awards. Junior memberships shall have one vote each.
- 4 It is required that the owner or exhibitor of any horse participating in the Annual Awards in classes for exhibitors 18 years and under, other than equitation, must be a KSHA member.
- 5 Family Membership-- For immediate family members (not cousins or in-laws, etc.). All are eligible for awards in their respective age groups. Two (2) votes per membership, and two family members must be present to utilize the two votes.
- 6 Horse Nomination Fee--An annual fee of \$10.00 is required for all horses competing for Annual Awards. It is transferable to a new owner and points accumulated stay with the horse.
- 7 Member show Fees per Judge per Day- \$35 for 'A' shows and \$40 for 'AA' shows, effective March 1, 2005. Each show will also provide KSHA with \$1 per horse per show following the show.

APPROVED CLASSES

The Following is a list of classes that are approved by KSHA for use in Member shows. Other classes may be added to suit local interest but cannot be counted toward the Annual Awards. **EXHIBITORS MUST PLACE IN AT LEAST THREE CLASSES IN ACCREDITED MEMBER SHOWS TO QUALIFY FOR AN AWARD IN EACH TYPE OF CLASS.**

1. Registered American Saddlebred Horses

Performance Division

- A. Fine Harness
Points from these following classes will count toward one year-end award.
Open (mares, stallions, geldings, stake)

Junior Horses, Open (4 and under, stake)
Amateur (mares, stallions, geldings, stake)
Ladies (mares, geldings, stake)

B. Five Gaited
Open (mares, stallions, geldings, stake)
Junior Horse (3 and under, 4 and under, stake)
Amateur (mares, stallions, geldings, stake)
Ladies (mares, geldings, stake)
Youth

C. Three Gaited
Open (over 15.2, 15.2 and under, stake)
Junior Horse (3 and under, 4 and under, stake)
Amateur (over 15.2, 15.2 and under, stake)
Ladies (over 15.2, 15.2 and under, stake)
Youth

Show Pleasure Division

Reg. American Saddlebred Show Pleasure, Amateur
Three-Gaited English any age (stake)
Three-Gaited English, 18 and under
Three-Gaited English, 19 and over
Five Gaited, any age
Pleasure Driving, any age

Country Pleasure Division

Reg. American Saddlebred Country Pleasure, Amateur
Three-Gaited English, any age (stake)
Three-Gaited Western, any age
Five-Gaited, any age
Pleasure Driving, any age
Pleasure Driving Combination, any age
Registered American Saddlebred Country Pleasure
Hunter

Halter Division

Registered American Saddlebred any age, any sex (includes age
and sex splits)

2. Registered Appaloosa and POA Horses

All points from splits (age or sex) go into the approved class.

- A. Registered Appaloosa English Pleasure, Open
- B. Registered Appaloosa Western Pleasure, Open
- C. Registered Appaloosa Halter, any age, any sex

3. Registered Arabian and Half-Arabian Horses

All points from splits (age or sex) go into the approved class.

- A. English Pleasure
Registered Arabian and Half-Arabian English Pleasure,
Open (Hunt or Saddle Seat)
- B. Hunter Pleasure
Registered Arabian and Registered Half-Arabian
Hunter Pleasure, Open
- C. Western Pleasure
Registered Arabian and Half-Arabian Western
Pleasure, Open
- D. Native Costume
Registered Arabian and Half-Arabian Native Costume,
Open
- E. Pleasure Driving
Registered Arabian and Half-Arabian Pleasure
Driving, Open
- F. Halter
Registered Arabian and Half-Arabian Halter, any age,
any sex

4. Disciplined Rail

5. English Pleasure

- A. Saddle Seat Pleasure
Open
18 and under (if split at time of show because of
the size of the class, AND all ages are

offered, points will count)
19 and over

- B. Beginners Walk-trot Pleasure
(may not enter a canter class)
(All points from splits go into the approved class)
Saddleseat, 18 and under
Huntseat, 18 and under
19 and over (Hunt or Saddleseat)
- C. English Saddle Seat Pleasure, Limited
Any age, breed, or sex horse, any age rider
- D. English Pleasure, Open (Hunt or Saddleseat)
Walk/Trot Open (all ages)

6. Equitation Division

- A. Bareback Equitation
18 and under
19 and over
- B. Beginners Equitation, Walk-Trot only
(All points from splits go into the approved class)
Western, 18 and under
Saddle Seat, 18 and under
Hunt Seat, 18 and under
Western, 19 and over
English, 19 and over (Hunt or Saddleseat)
- C. Hunt Seat Equitation, not to jump
18 and under
19 and over
- D. Saddle Seat Equitation
18 and under
19 and over
- E. Saddle Seat Pleasure Equitation
18 and under
19 and over
- F. Stock Seat Equitation
(Western Horsemanship)
18 and under
19 and over
Walk/Trot Open (all ages)

- G. English Equitation (Hunt or Saddleseat)
Walk/Trot Open (all ages)
7. **Fox Trotters**
 - A. Open, rider any age
 - B. Junior Horse, 3 and under, no canter
 - C. Ladies, no canter
 - D. Youth, no canter
 8. **Hunter**
 - A. Hunt Seat Pleasure
Open
18 and under
19 and over
Junior Horse 5 & under
Senior Horse 6 & over
 - B. Hunter Hack, any age
(Walk, trot, canter, jump 2' to 2'6")
 - C. Show Hack, Open
 9. **Leadline**
 10. **Miniature Horses**
 - A. Miniature Horse Driving
 - B. Miniature Horse Halter
 11. **Registered Morgan Horses**
 - A. Registered Morgan English Pleasure, Open (Hunt or Saddle Seat)
 - B. Registered Morgan Western Pleasure, Open
 - C. Registered Morgan Pleasure Driving, Open
 - D. Registered Morgan In-hand, any age, any sex
 12. **Registered Paint/Pinto Horses**
 - A. Registered Paint/Pinto English Pleasure, Open (Hunt or Saddleseat)
 - B. Registered Paint/Pinto Western Pleasure, Open
 - C. Registered Paint/Pinto Halter, any age, any sex
 13. **Registered Palomino/Buckskin/Dun Horses**
 - A. Registered Palomino/Buckskin/Dun English Pleasure,
Open (Hunt or Saddleseat)
 - B. Registered Palomino/Buckskin/Dun Western Pleasure,
Open
 - C. Registered Palomino/Buckskin/Dun Halter, any age,
any sex

14. **Paso Fino Horses**
 - A. Bella Forma (In-hand), Open
 - B. Paso Pleasure, Open (Peruvian Paso allowed)
 - C. Paso Fino Performance, Open

15. **Pleasure Driving**
 - A. Pleasure Driving, Open
 - B. Prairie Pleasure Driving, Open

16. **Pony Division**
 - A. Harness Show Pony, 50" and under
 - B. Pony Pleasure Driving, under 14.0
 - C. Roadster Pony, Open
 - D. Pony Pleasure, under 14.0
 - E. Pony Halter, any age, any sex

17. **Registered Quarter Horses**
 - A. Registered Quarter Horse Hunter Under Saddle, Open
 - B. Registered Quarter Horse Western Pleasure, Open
 - C. Registered Quarter Horse Halter, any age, any sex

18. **Reining Open**

19. **Roadster Horses**
 - A. 14.2 and over to bike
 - B. 14.1 and under to bike
 - C. 14.2 and over under saddle
 - D. 14.1 and under to be under saddle
 - E. 14.2 & over combination
 - F. 14.1 and under combination

20. **Sidesaddle Ladies**

21. **Showmanship at Halter**

All points from splits go into the approved class

 - A. Beginner's Showmanship
 - B. 18 and under (includes all splits)
 - C. 19 and over

22. **Registered Tennessee Walking Horses**
 - A. Show Division
 - Open (mares, stallions, geldings, stake)
 - B. Pleasure Division
 - Walking Horse Country Pleasure
 - Walking Horse Plantation Pleasure, Open
 - Walking Horse Park Pleasure, Open
 - Walking Horse Park Pleasure, Specialty, Amateur

- C. Walking Horse Show Pleasure, Amateur
Halter Division
(Includes age and sex splits)
Registered Tenn. Walking Horse, Halter, any age/sex

23. Trail Horse

- A. Open
- B. Beginner Walk-Trot
- C. In-Hand Trail

24. Versatility Class

25. Western Pleasure

- A. Open Division
Western Pleasure, Junior Horse (5 and under)
Western Pleasure, Senior Horse (6 and over)
Western Pleasure, Ladies (19 and over)
Western Pleasure, Men's (19 and over)
Western Pleasure, 18 and under (if split at time of
show because of the size of the class, AND all
ages are offered, points will count)
Western Pleasure, Open
Western Pleasure Walk-Trot Open
- B. Beginners Walk-Trot Division
All points from splits go into the approved class.
18 and under
19 and over

26. Western Riding

CLASS DESCRIPTIONS

1. REGISTERED AMERICAN SADDLEBRED HORSES

Registration with the American Saddle Horse Association, Inc. required.

Performance Division

Stallions prohibited in Ladies and Youth classes. No artificial appliances except mane and tail hair, tail braces, and mouth controls. Stripping of horses is mandatory in under saddle championships. Two (2) attendants only.

- A. Fine Harness
Shown with full mane and tail
Animated walk, Park trot, Show Your Horses
Stand quietly. Not required to back
4-wheel buggy without top
Light harness, snaffle bit and overcheck with blinkers
Quarter boots permitted
Attendant permitted in line-up
- B. Five-Gaited
Shown with full mane and tail
Walk, trot, slow gait, rack, canter
Quarter boots permitted
- C. Three-Gaited
Roached mane and tail
Walk, trot, and canter

Show Pleasure Division

Amateur and youth exhibitors only. Stallions prohibited in all classes. Shoe bands and pads are permitted. Cross entry between Pleasure and Country Pleasure and between three- and five-gaited classes is prohibited at the same show. Shown with full mane and tail. Tail sets and ginger prohibited. Pulling, tossing head, going sideways, and switching tail are to be penalized. Emphasis on walk. Judged 75% on performance, presence, quality and manners, 25% on total conformation with breed standards.

- A. Three-Gaited English
Flat walk, trot, and canter
Stand quietly and back readily
Full bridle, pelham, or curb only

Ring snaffle prohibited

- B. **Five-Gaited**
Flat walk, trot, slow gait, rack, and canter
Stand quietly and back readily
Full bridle, pelham, or curb only
Ring snaffle prohibited
Quarter boots permitted

- C. **Pleasure Driving**
Flat walk, trot, and extended trot
Stand quietly and back readily
Light harness with snaffle bit and separate overcheck bit, two-wheeled buggy
Headers permitted in line-up at the judge's and show manager's discretion

Country Pleasure Division

Same general description as under Show Pleasure Division. Must be plain shod, no pads. Emphases on walk, 75% on manners and performance, presence, and quality, 25% conformation and neatness of attire with breed standard.

- A. **Three-Gaited English**
Flat walk, trot, extended trot, and canter
Stand quietly on rail and in line-up
Back readily

- B. **Three-Gaited Western**
Flat walk, jog, lope or canter
Stand quietly on rail and in line-up
Back readily
Western Headstall without noseband
Standard Western bit
Ropes, chaps, and ties optional

- C. **Five-Gaited**
Flat walk, trot, slow gait, rack, and canter
Stand quietly on rail and in line-up
Back readily

- D. **Pleasure Driving**
Flat walk, trot, and extended trot
Stand quietly on rail and in line-up
Back readily
2- or 4-wheeled buggy with appropriate harness

Headers permitted in line-up at judges and show manager's discretion
Overcheck with separate overcheck bit or sidecheck (separate side check bit is optional) and snaffle bit (straight or jointed).

- E. Hunter
Walk, trot, canter, stand and back.
Extended trot and hand gallop optional.
No more than eight (8) horses may hand gallop at a time.
Natural tail carriage.
May be braided hunter style.
Bridle to be snaffle, pelham, full bridle, kimberwicke, light show type, single curb, single snaffle or light bridle.
No martingale or tie down.
- F. In-hand Division
Shown in bridle or in-hand
Entry must be serviceably sound
Two attendants per animal allowed
Shown individually standing and at a walk and trot on the line
50% conformation with breed standards and finish
50% way of going and natural action

2. REGISTERED APPALOOSA HORSES

Registration with the Appaloosa Horse Club, Inc. or Pony of America Club required. Stallions prohibited in youth classes. 60% performance and manners; 30% type, conformation with breed standards, quality and substance; 10% appointments.

- A. English Pleasure
Walk, trot, canter with ability to push on
Double or single rein bridle
- B. Western Pleasure
Walk, jog, and lope with ability to push on
Standard Western bits including snaffle bits and bosals
No curb chains or straps less than 1/2" in width
Ropes, chaps, ties optional

C. Halter

Shown in Halter only. Not to stretch. No whips. No coloring on hooves. Judged individually standing and at a walk and trot on the line. One handler. 40% conformation with breed standards, 20% type, 20% action. 20% soundness.

3. REGISTERED ARABIAN & HALF-ARABIAN HORSES

Registration with the AHA (Arabian Horse Association) required. Arabs are shown with natural, unbraided mane and natural, unset, ungingered tail. Shoeing: Maximum length toe 4 1/2", maximum weight shoe, 14 oz.; 1 pad not exceeding 3/8". Youth prohibited from showing stallions.

Half-Arabians must be registered with AHA in the Half-Arabian Registry. They shall be judged on quality, conformation with breed standards, substance and type. Half-Arabian colts/stallions may compete in weanling and yearling halter classes, however at two (2) years and over they are excluded from all halter classes. Half-Arabian colts/stallions may not compete in performance classes. Half-Arabian hunter types, showing under hunter tack, are permitted to carry a braided mane and tail.

A. English Pleasure

Flat walk, normal trot, strong trot, canter, hand gallop; extreme speed to be penalized

Full bridle, pelham, single curb, and single snaffle permitted

Hunt or Saddle seat equipment

Stand quietly and back readily

B. Hunter Pleasure

Walk, trot, canter, hand gallop

Back readily and stand quietly

Judged on manners, performance, suitability as a Hunter, quality and conformation with breed standards
Horses may be braided

Colored browbands and cavessons not permitted

C. Western Pleasure

Flat walk, jog trot, lope, hand gallop; extreme speed to be penalized

Western headstall without noseband, standard Western bit

Bosals permitted on horses 5 years and under.

Ring snaffle bits with 2-4" rings permitted on horses 5

years and under.
No curb chain or strap less than 1/2" in width
Stand quietly and back readily
Ropes, chaps, ties, optional

- D. Native Costume
Walk, canter, hand gallop; extreme speed to be penalized
Stand and back
Bridle with bosal or bit.
Fringe or tassels may be added to all equipment.
Rider's attire: flowing cape or coat, pantaloons, headdress, scarf, or sash.
75% performance and manners; 25% for appointments.
- E. Pleasure Driving
Walk, trot, strong trot
Stand quietly and back readily
2 or 4 wheeled vehicle; light harness, bridle with blinkers, snaffle bit, overcheck or sidecheck with separate bit.
Headers permitted
- F. Halter
Shown in-hand at a walk and trot. Not to be stretched. A suitable headstall equipped with throatlatch is mandatory. Excessive use of the whip to be penalized. Arabians to be judged on type, conformation with breed standards, substance and quality. Transmissible weaknesses to count strongly against breeding stock.

4. **DISCIPLINED RAIL**

Riders may show western, hunt, or saddleseat. Splits approved if all splits are offered (may combine hunt and saddleseat as one split). This class is not a game or a fault-and-out competition, but shall be judged based on performance. The judge shall determine the gaits to be called and their order, but safety should be a priority. The judge shall NOT ask participants to dismount. The class will be worked collectively on the rail, and the routine may include but is not limited to:

- Walk, jog, trot (a posting trot should only be called if the class is limited to English riders), and canter/lope
- Hand gallop (no more than 8 horses to hand gallop at a time)
- Simple or flying lead changes
- Loping from a halt

- Counter-cantering or counter-lopings
- Sidepass or leg yield
- Turn on hindquarter and/or forequarter
- Back

5. ENGLISH PLEASURE

Open to all horses. 70% performance and suitability; 30% conformation with breed standards

- A. Saddle Seat
Walk, trot, canter, stand, and back
Extended trot optional
Normal tail carriage. May be braided.
Bridle to be light show type, single curb or single snaffle, full bridle or pelham bit. No martingale or tiedown.
- B. Beginner Walk-Trot English Pleasure
Walk, trot, and back
60% performance, 30% conformation with breed standards, 10% costume
Limited to riders who have not ever shown in any classes in a KSHA show where a canter is a required gait.
Riders remain eligible until they enter a KSHA class requiring a canter.
- C. English Saddle Seat Pleasure Limited
Horse cannot have won six (6) blue ribbons in any walk/trot/canter class requiring saddle seat equipment.
Any age, breed, or sex horse
Any age rider
Walk, normal trot, canter; back optional
Bridle to be light show type, single curb or single snaffle, curb and snaffle or pelham bit. No martingales or tiedowns.

6. EQUITATION DIVISION

Rider only being judged. Any type horse. Money prizes prohibited. A pattern is optional for Bareback Equitation and Saddle Seat equitation. For Hunt Seat Equitation and Stock Seat Equitation (Western Horsemanship), a written routine will be followed. For Beginners Equitation Walk Trot Only classes for riders 18 years and under (including splits), the judge may choose one of four suggested patterns found in the KSHA

rulebook or supply a pattern of similar difficulty. For Beginners Equitation Walk Trot Only classes for riders 19 years and over, patterns are required but will be determined by the judge. Individual workouts will be first with rail work second. Each show's judge must supply a separate written routine (pattern) for each division. Patterns are to be posted at least 1 hour before the show starts, and should be workable in 1 minute or less. In Classes with mandatory workouts, rail work shall be optional.

- A. Bareback Equitation
Walk, trot, canter, may not be asked to dismount
Reverse towards or away from the rail.
Western or English attire, chaps optional.
- B. Beginners Equitation, Walk and Trot only
English or Western equipment and attire
Limited to riders who have not ever shown in any class
in a KSHA show where a canter is a required
gait.
Riders remain eligible until they enter a KSHA class
requiring a canter or lope.
- C. Hunt Seat--not to jump
Walk, slow trot, posting trot, canter, hand gallop
Full bridle, pelham or single snaffle with cavesson
Patterns are required
Hunt Coat, Breeches or Jodhpurs, Jodhpur boots or
Hunt boots, Suitable Hunt Hat.
Spurs, crops or bats optional.
- D. Saddle Seat
Exhibitor may not cross enter Saddle Seat or Saddle
Seat Pleasure Equitation at any show.
Walk, trot, and canter
Full bridle (curb and snaffle) or pelham
Riding habit required with derby and Jodhpur boots
Optional: workout
- E. Saddle Seat Pleasure
Exhibitor may not cross enter Saddle Seat or
Saddleseat Pleasure Equitation at any show.
Walk, trot, and canter
Full bridle (curb and snaffle) or pelham
Informal riding habit with derby and Jodhpur boots
required
Optional: workouts

Must ride a pleasure horse of any breed.

- F. Stock Seat (Western Horsemanship)
Walk, jog, lope
Standard western bit, no curb chain or strap less than ½" in width.
Bosal or snaffle on Junior Horses (5 years and under) accepted. May be ridden with two hands.
Boots, hats, long sleeve shirts required.
Ropes, chaps, and ties optional.
Patterns are required. Time limit is one minute per exhibitor.

7. FOXTROTTERS

Flat walk, foxtrot, and canter
Browband type bridle with or without cavesson
Western style saddle
Standard western bit, with no curb chain or strap less than 1/2" in width
Ladies, youth, and junior horses will not canter

8. HUNTER

Any breed, height, or sex horse. Must be serviceably sound.
Snaffle, pelham, full bridle, or kimberwicke. Judged on even hunting pace, manners and jumping style.

- A. Hunt Seat
Walk, trot, canter, stand and back
Extended trot and hand gallop optional
No more than 8 horses may hand gallop at a time.
Natural tail carriage
May be braided per breed specifications.
Bridle to be a snaffle, pelham, full bridle or kimberwicke.

- B. Hunter Hack
Walk, trot, canter; gallop one-way
Jump two (2) fences from 2' to 2'6" in height
Require jumps to be spaced in increments of 12' with a minimum of 48' between jumps and a maximum of 72'
Drop noseband prohibited
Protective boots and leg wraps are acceptable.

- C. Show Hack, Open
Mane and tail may be braided or roached
English saddle of any type is required
Bridles may be double, pelham, snaffle, full, or
kimberwicke.
Drop nosebands prohibited.
Martingales, breastplates, boots and/or bandages
prohibited
Browbands and cavessons other than Hunter or
Dressage types are prohibited.
Acceptable hack attire is required
Saddle suit and/or Kentucky jodhpurs are prohibited
Horses must enter ring at a walk
To be shown at a walk, trot, canter, hand gallop, stand
and back readily; collected and extended gaits
to be called for.
Mounting, dismounting and rein back may also be
required
To be judged 55% performance; 20% quality, 15%
conformation with breed standards, 10%
manners

Show Hack Gaits defined:

Walk--straight, four beat and flatfooted

Trot--free, light and crisp, may be required as follows:
free on a light contact, collected with rider
sitting, extended--on contact--medium speed
with legs moving forward with impulsion and
with rider posting or sitting.

Canter may be required as follows, collected, normal,
extended, hand gallop under control.

****NOTE: ANY GAIT CAN BE REQUIRED FROM HALT.****

A well-trained show hack will be able to perform all of
these gaits with a noticeable difference in performance,
as changes are made from collected to extended gaits.

9. LEADLINE

Rider must be three years or over. Leader must be 14 years and
over. Any type horse or pony may be used. Judged on rider's
ability, neatness and coordination of attire. (Equipment must be
adjusted to rider.) Walk only. No patterns. Costumes may be
worn. Has not ridden in any other performance class requiring a
gait other than a walk.

10. MINIATURE HORSES

Registration with the American Miniature Horse Association or the American Miniature Horse Registry is required.

- A. Halter
Horses to be shown in hand at the walk and trot.
Horses must also be viewed in motion from the side.
In the case of two animals being judged equal, the higher placement shall be awarded to the SMALLER ANIMAL. In no case, however, shall a smaller horse be placed over a larger horse with better conformation.
- B. Open Driving
Gait requirements-Pleasure driving is to be shown both ways of the arena at a Walk, Pleasure Trot, and an Extended Trot. Horses will enter the ring counter clockwise at a Pleasure Trot. Horses will be required to stand quietly and rein back.

11. REGISTERED MORGAN HORSES

Registration with the American Morgan Horse Association, Inc. required. Shown with full mane and tail carried naturally. Shoeing: maximum length toe, 4 3/4"; maximum weight, 18 oz., including pads. Stripping of horses in under saddle championships is mandatory. 60% manners and gait; 40% type and conformation with breed standards.

- A. English Pleasure
Flat walk, pleasure trot, road trot, and canter
Full bridle and saddle seat attire OR Pelham or single snaffle and hunt seat attire
Hunt or Saddle Seat Equipment
- B. Western Pleasure
Flat walk, jog, lope
Standard western bit with no curb chain or strap less than 1/2" in width
Bosals and ring snaffles with 2-4" rings permitted on horses 5 years and under
Ropes, chaps, ties optional
- C. Pleasure Driving
Flat walk, pleasure trot, and road trot
2-Wheel vehicle, light harness with overcheck or sidecheck
Header required without whip

- D. In-hand
Judged individually standing, and at a walk and trot on the line
Must be serviceably sound
Two handlers permitted

12. REGISTERED PAINT/PINTO HORSES

Registration with the American Paint Horse Association or the Pinto Horse Association of America, Inc. or any accredited color registry required. Registered breeding stock horses are eligible to show.

- A. English Pleasure
Walk, trot, canter; gallop optional
Hunt seat or saddle seat equipment
Full bridle, pelham, single curb, single snaffle or kimberwicke
- B. Western Pleasure
Walk, jog, lope
Standard western bit with no curb chain or strap less than 1/2" in width
Bosals and ring snaffles with rings 2-4" may be used on horses five years and under
Ropes, chaps, and ties optional
- C. Halter
Shown in hand at a walk and trot
Stock type to stand squarely; saddle type may be stretched
Judged on conformation with breed standards, quality, substance, and soundness
Color pattern not to count

13. REGISTERED PALOMINO/BUCKSKIN/DUN HORSES

Registration with the Palomino Horse Association, the Palomino Horse Breeders of America, The American Buckskin Registry of America, or The International Buckskin Horse Association required.

- A. English Pleasure
Walk, trot, canter; hand gallop optional
Stand quietly and back readily
Hunt seat or Saddle seat equipment
Full bridle, snaffle, pelham, or kimberwicke bit; with cavesson
- B. Western Pleasure
Walk, jog, and lope
Stand quietly and back readily
Bosal or curb, snaffle, half-breed, spade bits
permissible with no curb chain or strap less than 1/2 " in width.
Ropes, chaps, and ties optional
- C. Halter
Shown in halter or bridle
Judged individually standing, and at a walk and trot on the line
65% conformation with breed standards, 25% color, 10% manners and way of going

14. PASO FINO HORSES

Reference "Paso Fino Conduct and Specifications" sheet in Judge's Packet.

- A. Bella Forma (In-hand)
Shown in a leather show in-hand without a bit.
Matching lead line or long lines required
Conformation with breed standards and gait to be judged
Qualifying Gaits: Classic Fino or Paso Corto
Choice of gaits is optional, with no preference to be given one over the other
Judged 60% conformation with breed standards, 30% on quality and naturalness of gait, and 10% on appearance, grooming and manners.
- B. Paso Pleasure (Peruvian Paso Permitted)
Flat walk: A true, evenly spaced 4 beat
Paso Corto: Mild collection
Paso Largo: Mild collection
Refusal to back disqualifies horse from placing
Dismount and mount may be called for at

judges' discretion.
Judged 30% on the Paso Corto, 30% on the Paso Largo, 20% on manners, attitude, and way of going, 10% on the flat walk, and 10% on backing
Tack and headgear for horses should be of a variety appropriate and practical for pleasure riding.
Attire shall be long sleeved shirt, full-length trousers, riding boots or shoes.
Hats and jackets are optional

- C. Paso Fino Performance
Walk (collected)
Paso Corto (collected)
Paso Largo (collected)
Judged 30% on the Paso Corto, 30% on the Paso Largo, 15% on the walk, 15% on appearance and way of going, and 10% on manners
English type tack
Attire must be official Paso Fino show costume

15. PLEASURE DRIVING, OPEN

Any breed horse, 2- or 4- wheeled vehicles with light harness, bridle and blinkers, snaffle bit with overcheck or sidecheck. Shown with full mane and natural tail. No quarter boots. Judged on performance, manners and suitability.

- A. Pleasure Driving Open
Walk, normal trot, strong trot
Stand quietly and back readily
Attendant in lineup permitted
- B. Prairie Pleasure Driving Open
Open to western or hunter type horses, any size
Horses shown saddle seat at a KSHA show are not eligible in the same calendar year
Vehicle to be in safe and sound condition, 2- or 4 wheeled type, no preference is to be given in judging.
Harness to be light use harness or show harness in breast collar or full collar type.
Flat walk, regular trot or optional gait and drive on

May be asked to back
Choice of attire is by discretion (must be neat and in good taste)
Judged 70% on manners and performance, 15% on neatness, 15% on overall appearance.
Attendant in lineup permitted.

16. PONY DIVISION

A pony is defined as any equine 14 hands and under. Horses registered with the American Miniature Horse Association or the American Miniature Horse Registry are not allowed in Pony classes.

- A. Harness Show Pony
Maximum height 50"—long mane and tail
4-wheel buggy, overcheck is prohibited
Shown at park trot and smart trot
Headers permitted
- B. Pony Pleasure Driving
Must be under 14.0 hands, any breed
Walk, normal trot, and brisk trot
Stand quietly and back readily
- C. Roadster Pony
Maximum Height 50"—Emphasis on the trot at three speeds, slow jog trot, fast road trot, and full speed.
Enter ring in clockwise direction
Judged on performance, speed, quality, and manners
- D. Pony Pleasure
Must be under 14.0 hands, any breed
Walk, trot, and canter
English or western
- E. Pony Halter
To be shown in halter or bridle, standing and in action, on the rail in hand. Maximum Height 14.0H

17. REGISTERED QUARTER HORSES

Registration with the American Quarter Horse Association is required.

- A. Hunter Under Saddle
Walk, trot, canter; hand gallop optional
No more than eight (8) horses to hand gallop at a time
Hunt seat equipment only
Reverse to center only
- B. Western Pleasure
Walk, jog, lope
Any standard western bit with no curb strap or chain
less than ½" in width
Bosals and ring snaffles with 2-4" rings permitted on
horses five years and under
Reverse to center only
- C. Halter
Judged individually, standing and at a walk and trot on
the line
Must be shown in a halter
Must stand squarely

18. REINING OPEN

Bosal or loose cavesson type noseband permitted
Riders' hands must stay clear of horse and saddle
Horses to rein and handle easily with reasonable speed
Collective rail work is not required
Exhibitor may show more than one horse
Pattern to be posted by the judge prior to the start of the show
from optional patterns listed at the back of the book.

19. ROADSTER

Emphasis on trot at three speeds: slow jog trot, fast road trot,
and full speed
May be asked to walk, enter clockwise
Stand quietly and back readily
No headers allowed
Must wear colors
Shown to bike or wagon: Harness with square
blinkers, snaffle bit, and check rein is required
Shown under saddle with English Saddle, full martingale, open
bridle with snaffle bit, single or double rein, and
quarter boots.

- G. 14.2 and over to bike
- H. 14.1 and under to bike
- I. 14.2 and over under saddle
- J. 14.1 and under to be under saddle
- K. 14.2 & over combination
- L. 14.1 and under combination

20. SIDESADDLE LADIES

English, western, or period saddles with corresponding attire permitted. All points from splits (English, Western, and Period) go into the approved class.

Walk, jog or normal trot, lope or canter

Rider may sit or post the trot

Not to be judged as a costume class

75% manners, performance, quality and conformation with breed standards; 25% appropriate sidesaddle dress

21. SHOWMANSHIP AT HALTER

Only the showman is to be judged, the horse is merely a prop to show the ability of the showman. Showmanship at halter shall be a separate class from all other in-hand or halter classes. This performance class shall be judged strictly on the contestant's ability to fit and show in an in-hand or halter class. Showmanship at Halter pattern is required. Pattern to be determined by the judge and must be posted prior to the first class of the show.

Beginner's Showmanship at halter, must be accompanied by someone over the age of 14 to assist. The exhibitor cannot have shown in any other in-hand or halter class. Proper show ring attire should be worn by exhibitor and assistant.

APPEARANCE OF HORSE (40 points)

Horse to be in good show condition, well groomed with hair coat clean and well brushed. Mane and tail should be clean and free of tangles. Hoofs must be trimmed properly. If shod, shoes must fit properly and clinches should be neat. Horses should be groomed per breed specification. Tack should be neat, clean, and in good repair. Quarter boots are prohibited for American Saddlebred horses.

APPEARANCE OF EXHIBITORS (10 points)

Clothes and person should be neat and clean. The showman should wear suitable Western or English clothes.

SHOWING HORSE IN RING (50 points)

Walk on horse's left side, holding lead shank in right hand near halter. A tightly coiled or rolled lead shank will be considered a fault in showmanship. Horse should lead readily at a walk or trot.

A pattern will be posted which requires each exhibitor to work individually. When moving the horse, be sure that the judge gets a clear, unobstructed view of the horse's action. Allow the horse sufficient lead so that he can move freely and in a straight line. Lead the horse from his left side the required distance, stop and turn to the right around the horse.

When posing the horse, stand toward the front facing the horse, but always in a position where you can keep your eye on the judge. Pose your horse with its feet squarely under it. Do most of the showing with the lead shank. Never kick your horse's leg into position. Do not crowd exhibitors next to you when lined up head to tail. When judge is observing the other horses, let yours stand if posed reasonably well. Be natural. Over showing, undue fussing and maneuvering are objectionable. For example, a 90 degree left turn is preferable to a 270 degree right turn, unless the 270 degree right turn is specifically called for in the pattern.

Keep alert and aware of the position of the judge at all times. Do not be distracted by persons or things outside the ring. Show horse at all times. Respond quickly to requests from the judge and officials. Be courteous and sportsmanlike at all times. Recognize quickly and correct faults of your horse. Keep showing until the entire class has been placed and has been excused from the ring.

22. REGISTERED TENNESSEE WALKING HORSES

- A. Show Horse Division
 - Flat walk, running walk, canter
 - Judges will penalize entries out of form.
 - Only tail brace, switch, or humane tails allowed
 - Bumping and pumping penalized
 - A tendency to rack, pace, slow gait, or any other deviation from the true gaits shall be penalized
 - In championship classes, horses must be stripped
 - All horses exhibited must comply with USDA rules for shoeing, appliances used, and inspection
- B. Country Pleasure

Flat walk, running walk—NO CANTER
Stand quietly and back readily
Bumping and pumping to be penalized
Hoof bands, action devices, and pads prohibited
Ribbons are optional, tails must be natural
Western or English equipment
Shoe maximum ½" thick, 1 ½" wide with no bar plates
or weight inside shoe
Calks maximum ½" in width and length
Shoe must not extend more than ¼" beyond hoof on all
sides
Judged on manners, performance, quality, and
substance

- C. Plantation Pleasure Open
Flat walk, running walk, canter
Stand quietly and back readily
Bumping and pumping to be penalized
Hoof bands, action devices, and pads prohibited
Plain shod shoe maximum ½" thick, 1 ½" wide with no
bar plates or weight inside shoe
Ribbons are optional, tails must be natural
- D. Park Pleasure Open
A personal park pleasure mount
Flat walk, running walk, canter
Stand quietly and back readily
Bumping and pumping to be penalized
Hoof bands and action devices permitted
Ribbons are optional, tails must be natural
- E. Park Pleasure Specialty—Amateur
A personal park pleasure mount
Flat walk, running walk, NO CANTER
Stand quietly and back readily
Bumping and pumping to be penalized
Hoof bands and action devices permitted
Ribbons are optional, tails must be natural
- F. Show Pleasure—Amateur
Flat walk, running walk, canter
Stand quietly and back readily
Bumping and pumping to be penalized
Hoof bands permitted
Action devices prohibited
Ribbons are optional, tails must be natural

- G. Halter—Model class
Horses need not be shown in action
Emphasis placed on type, quality, presence, and
conformation with breed standards
Visible unsoundness and blemishes shall be penalized
Any age, Any sex

23. TRAIL HORSE

Course should be set up in a manner such that it may be executed in approximately five (5) minutes. Required to work over or through obstacles. Course must consist of at least five (5) obstacles. After three (3) refusals, the horse must move on to the next obstacle. Pattern must be posted by the judge prior to the start of the show. Western tack only is permitted.

Courses should be designed with safety in mind so as to eliminate any accidents. Obstacles may include but are not limited to:

- Opening, passing through, and closing gate.
- Ride over logs or poles. Poles can be in a straight line, curved, zigzag, or raised (maximum height 8").
 - Spacing for walkovers shall be 20" to 24"
 - Spacing for trotovers shall be 3' to 3'6"
 - Spacing for lopeovers shall be 6' to 7'
- Backing obstacle, such as a cloverleaf pattern, L, V, or U. Participants shall not be asked to back over an obstacle such as a pole.
- Serpentine obstacles at walk or jog (minimum of 6' for jog)
- Carry object from one part of arena to another (object must be small enough to carry without dragging and something that might be reasonably carried horseback).
- Ride over wooden bridge at a walk. Flat bridges may have an additional element such as a walkover pole.
- Put on and remove slicker.
- Remove and replace materials from mailbox.
- Sidepass (horses shall not be asked to sidepass with any object between their front and rear legs except for a wooden log or pole).
- Turn inside a square. Turns may be 180, 270, 360 or more degrees. Markers for the square may include wooden poles/logs, bridge, or cones.

Unacceptable obstacles include:

- Tires
- Animals
- Hides
- PVC pipe (exception: classes limited to horses/ponies 14.0 hands and under)
- Jumps
- Rocking or moving bridges
- Water box with floating or moving parts
- Flames, dry ice, fire extinguisher, etc.
- Logs or poles elevated in a manner that permits them to roll
- Ground poles made of foam ("noodles")
- Ground ties or dismount/remount (Dismounting is acceptable as part of the final obstacle if a remount is not required)

Horses are not to be required to work on rail. Course must be designed, however, to require each horse to show the required gaits according to the approved class (Open: walk, jog and lope; Walk-Trot: walk and jog only) somewhere between obstacles as part of its work.

Beginner Walk-Trot Trail is limited to riders who have not ever shown in any classes in a KSHA show where a canter or lope is a required gait. Riders remain eligible until they enter a KSHA class requiring a canter or lope.

In-Hand Trail is open to all horses regardless of age or breed, and all exhibitors except those currently competing in Beginner's Showmanship. Horses competing in in-hand trail may not compete in an under-saddle trail class at the same show. To be shown at a walk and trot. No tack except a halter and lead allowed. A silver show halter shall not be counted above a good working halter.

The trail horse class may be held in an adjacent area during the show and be judged by a qualified person.

Prior to the start of the class, the judge must walk the course and has the right to remove or change any obstacle he/she deems unsafe or non-negotiable. If three members of the Rules Committee deem an obstacle unsafe or non-negotiable, the obstacle will be repaired or removed. Riders will be permitted to inspect the course on foot without their horses during the judge's walk-through. At this time, at the judge's discretion, the riders may ask questions and/or the judge may walk the riders through the course. A minimum of five minutes, but not to exceed ten minutes, will be allowed for the walk-through.

24. VERSATILITY CLASS

This class is an all breed class in which the same rider shows the horse first under Western tack both ways of the ring and then under English tack both ways of the ring. Each entry is allowed two attendants and the time allowed to change the tack (without leaving the arena) will be at the discretion of the judge. No wheeled carrier or saddle/tack racks allowed. The class will be judged by both Western Pleasure and English Pleasure rules, with neither to count for more than 50% of the final decision.

25. WESTERN PLEASURE

- A. Western Pleasure
Walk, jog, lope (no lope in Western Pleasure Walk/Trot Open)
60% performance, 30% conformation with breed standards, 10% appointments
Stock saddle
Standard western bit with no curb chain or strap less than ½ " in width
Bosals and ring snaffles with 2-4" rings may be used on horses 5 years and under
Hackamores, cavessons, martingales, and tiedowns prohibited
Ropes, chaps, and ties are optional
- B. Beginners Walk/Trot Pleasure
Walk, jog, stand and back
60% performance, 30% conformation with breed standards, 10% appointments
Stock saddle
Standard western bit with no curb chain or strap less than ½ " in width
Limited to riders who have not ever shown in any classes in a KSHA show where a canter or lope is a required gait. Riders remain eligible until they enter a KSHA class requiring a canter.

26. WESTERN RIDING

Western Riding is neither a stunt nor a race, but it should be done with reasonable speed. It is a competition in the performance of a sensible, well mannered, free and easy moving

ranch horse which can get its rider around on the usual ranch chores, over the trails, or give a quiet comfortable and pleasant ride in open country through and over obstacles.

Scoring will be 60 to 80, with 70 denoting an average performance.

The contestants will be judged on riding qualities of gaits (walk, jog, and lope), change of leads, response to the rider, manners, disposition and intelligence. It is important that the horse correctly change leads at the lope (flying change) while riding the pattern. Lead changes should be made as near the halfway point between markers as practicable.

The following pattern and routine are prescribed. It is essential that the judge and exhibitors adhere to it.

The nine (9) small o's with crosses in them represent markers (pylons are recommended). These should be separated by a uniform distance of not less than thirty nor more than fifty feet on the side, with five (5) markers. The rectangle represents an obstacle, (one small log is recommended), just high enough to break the animal's stride. The long and sometimes twisting lines indicate the direction to travel and the gaits at which the horse is to move. The dotted line indicates walk, the dashed line jog, and the solid line lope.

Any horse not following the exact pattern will be disqualified. The judge may require an exhibitor to repeat any part of the routine. Except for junior horses shown in a hackamore or snaffle bit, only one hand may be used on the reins and hands must not be changed.

Hands to be around reins, index finger only between reins is permitted. While the horse is in motion, the rider's hands shall be clear of the horse and the saddle. Spurs or romal shall not be used forward of the cinch.

Exhibitors will enter individually to work the pattern. A copy of the required pattern for this class will be posted before the class begins.

Instructions for the pattern are:

1. Walk and jog over log.
2. Transition to left lead and lope around end.

3. First line change.
4. Second line change.
5. Third line change.
6. Fourth line change lope around the end of the arena.
7. First crossing change.
8. Second crossing change.
9. Lope over log.
10. Third crossing change.
11. Fourth crossing change.
12. Lope up the center, stop, and back.

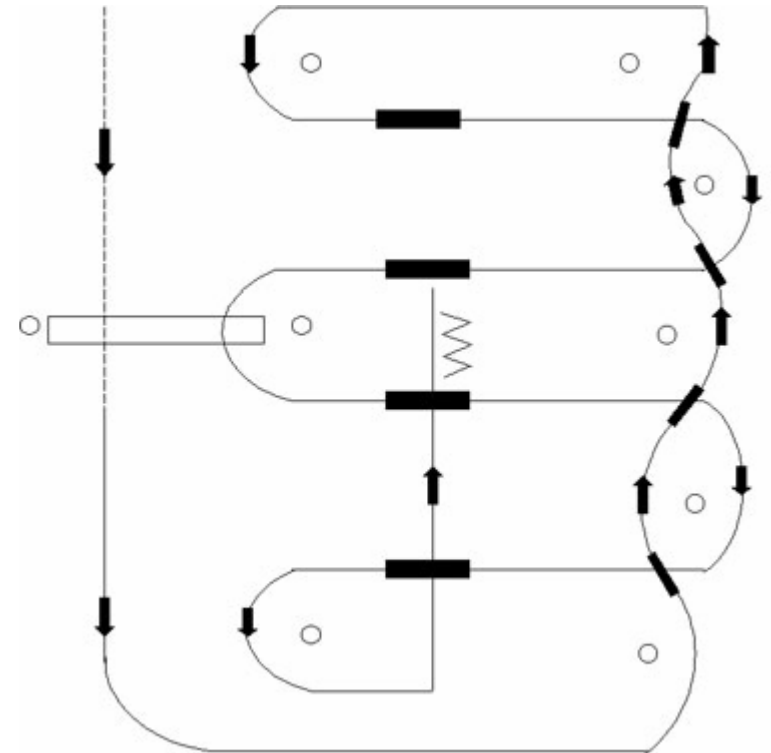

REINING PATTERNS

REINING PATTERN NUMBER 1

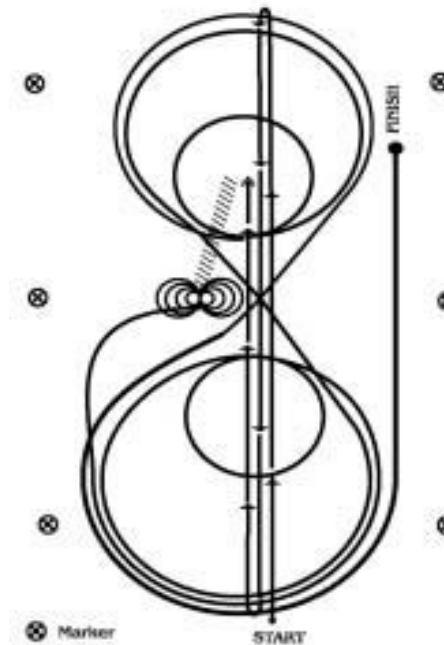

1. Run at speed to the far end of the arena past the end marker and do a left rollback - no hesitation.
2. Run to the opposite end of the arena past the end marker and do a right rollback - no hesitation.
3. Run past the center marker and do a sliding stop. Back up to center of the arena or at least ten feet (3 meters). Hesitate.
4. Complete four spins to the right.
5. Complete four and one-quarter spins to the left so that horse is facing left wall or fence. Hesitate.
6. Beginning on the left lead, complete three circles to the left: the first circle large and fast; the second circle small and slow; the third circle large and fast. Change leads at the center of the arena.
7. Complete three circles to the right: the first circle large and fast; the second circle small and slow; the third circle large and fast. Change leads at the center of the arena.
8. Begin a large fast circle to the left but do not close this circle. Run straight up the right side of the arena past the center marker and do a sliding stop at least twenty feet (6 meters) from wall or fence. Hesitate to demonstrate the completion of the pattern.

Rider may drop bridle to the designated judge.

REINING PATTERN NUMBER 2

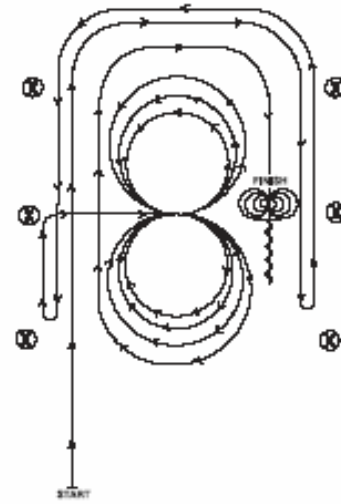

1. Beginning, and staying at least twenty feet (6 meters) from the walls or fence, lope straight up the left side of the arena, circle the top end of the arena, run straight down the opposite or right side of the arena past the center marker and do a left rollback - no hesitation.
2. Continue straight up the right side of the arena staying at least twenty feet (6 meters) from the wall or fence, circle back around the top of the arena, run straight down the left side of the arena past the center marker and do a right rollback - no hesitation.
3. Continue up the left side of the arena to the center marker. At the center marker, the horse should be on the right lead. Guide the horse to the center of the arena on the right lead and complete three circles to the right: the first two circles large and fast; the third circle small and slow. Change leads at the center of the arena.
4. Complete three circles to the left: the first two circles large and fast; the third circle small and slow. Change leads in the center of the arena.
5. Begin a large fast circle to the right but do not close this circle. Continue up the left side of the arena staying at least twenty feet (6 meters) from the wall or fence, circle the top of the arena, run straight down the opposite or right side of the arena past the center marker and do a sliding stop. Back up at least ten feet (3 meters). Hesitate.
6. Complete four spins to the right.
7. Complete four spins to the left. Hesitate to demonstrate completion of the pattern.

Rider may drop bridle to the designated judge.

REINING PATTERN NUMBER 3

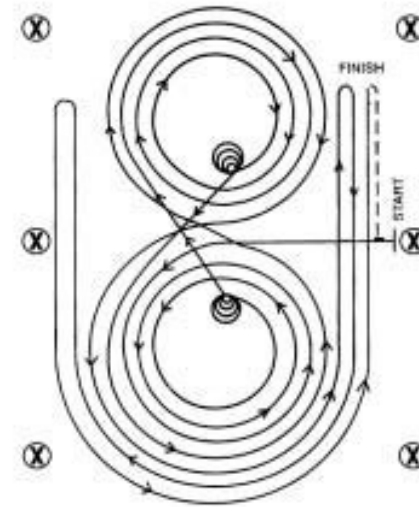

Horse must walk or stop prior to starting pattern.

Beginning at the center of the arena facing the left wall or fence.

1. Beginning on the left lead, complete three circles to the left: the first two circles large and fast; the third circle small and slow. Stop at the center of the arena.
2. Complete four spins to the left. Hesitate.
3. Beginning on the right lead, complete three circles to the right: the first two circles large and fast; the third circle small and slow. Stop at the center of the arena.
4. Complete four spins to the right. Hesitate.
5. Beginning on the left lead, run a large fast circle to the left, change leads at the center of the arena, run a large fast circle to the right, and change leads at the center of the arena. (Figure 8)
6. Continue around previous circle to the left but do not close this circle. Run up the right side of the arena past the center marker and do a right rollback at least twenty feet (6 meters) from the wall or fence - no hesitation.
7. Continue around previous circle but do not close this circle. Run up the left side of the arena past the center marker and do a left rollback at least twenty feet (6 meters) from the wall or fence - no hesitation.
8. Continue back around previous circle but do not close this circle. Run up the right side of the arena past the center marker and do a sliding stop at least twenty feet (6 meters) from the wall or fence. Back up at least ten feet (3 meters). Hesitate to demonstrate completion of the pattern.

Rider may drop bridle to the designated judge.

BEGINNER'S EQUITATION PATTERNS

In all patterns, where a Jog or Trot is called for, Western Riders should jog and English riders should trot unless specified otherwise.

BEGINNER'S EQUITATION PATTERN #1

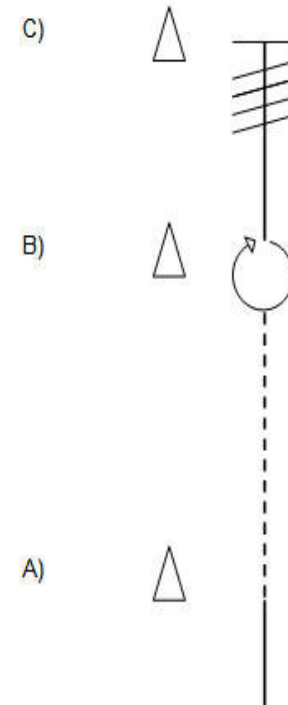

- 1) Walk to Cone A.
- 2) Jog or Trot to Cone B.
- 3) At B, Stop and perform a 360° turn in either direction (western riders turn on the hindquarters, English riders turn on the forehand.)
- 4) Walk to C. Stop and back 5 steps.

BEGINNER'S EQUITATION PATTERN #2

D)



C)



B)



A)



- 1) Walk to Cone A.
- 2) At Cone A begin jog/trot.
- 3) At Cone B, western riders extend the jog, English riders change diagonal and continue to trot.
- 4) At Cone C, western riders return to jog, English riders change diagonal.
- 5) At Cone D, break to walk and walk to lineup.

BEGINNER'S EQUITATION PATTERN #3

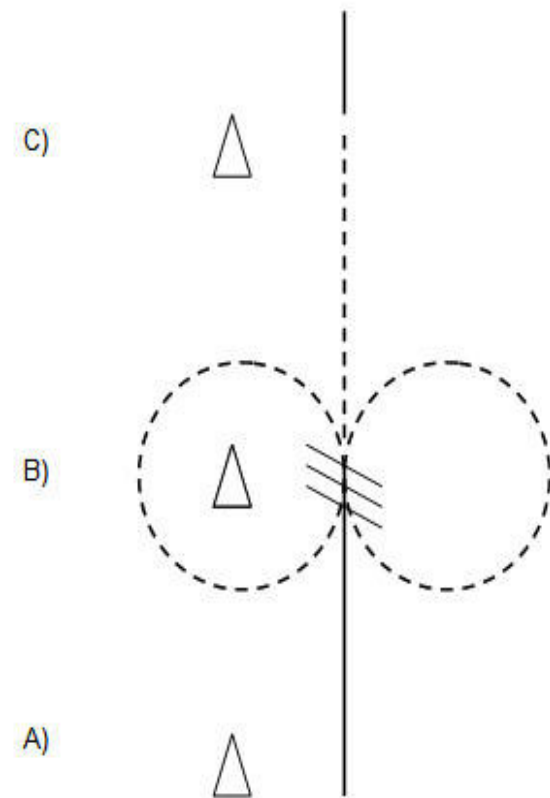

- 1) Walk from Cone A to Cone B. Stop at Cone B.
- 2) Back 3 steps.
- 3) Jog/Trot a figure 8.
- 4) Continue trotting to Cone C.
- 5) Walk and proceed to the lineup.

BEGINNER'S EQUITATION PATTERN #4

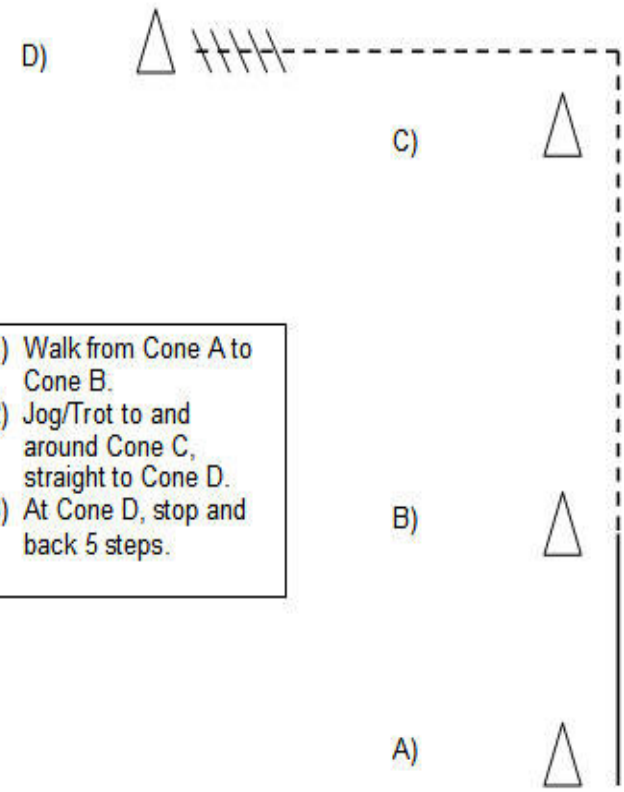

- 1) Walk from Cone A to Cone B.
- 2) Jog/Trot to and around Cone C, straight to Cone D.
- 3) At Cone D, stop and back 5 steps.